



Foster Prep Station with FD2-10 Controller



Service Manual



ISO 14001

ISO 9001



Contents









Manual Information & Health & Safety Notes	1
Environmental Management Policy	2
Disposal Requirements	2
Cabinet & Counter Description	3
Controller Relevance Table & Operation	3-4
User Functions	4-5
Defrost Operation & Fuzzy Logic	5
Wiring Diagram for Defrost & Technical Data	6
Configuration of Parameters	6
Prep Station Controller Default	7-10
Cabinet Arrangement Diagrams	11-12
Technical Data	13
Individual Unit Controller Parameter Values	14-16
Wiring Diagrams & Probe details	17-18
Troubleshooting & Notes	19-21

Service Manual Information

The products and all information in this manual are subject to change without prior notice. We assume by the information given that the person(s) working on these refrigeration units are fully trained and skilled in all aspects of their workings. Also that they will use the appropriate safety equipment and take or meet precautions where required.

The service manual does not cover information on every variation of this unit; neither does it cover the installation or every possible operating or maintenance instruction for the units.

Health & Safety Warnings and Information

	Make sure the power supply is turned off before making any electrical repairs.
	To minimise shock and fire hazards, please do not plug or unplug the unit with wet hands.
	During maintenance and cleaning, please unplug the unit where required.
	Care must be taken when handling or working on the unit as sharp edges may cause personal injury, we recommend the wearing of suitable PPE.
	Ensure the correct moving and lifting procedures are used when relocating a unit.
	Do NOT use abrasive cleaning products, only those that are recommended. Never scour any parts of the refrigerator. Scouring pads or chemicals may cause damage by scratching or dulling polished surface finishes.
	Failure to keep the condenser clean may cause premature failure of the motor/compressor which will NOT be covered under warranty policy.
	Do NOT touch the cold surfaces in the freezer compartment. Particularly when hands are damp or wet, skin may adhere to these extremely cold surfaces and cause frostbite.
	Please ensure the appropriate use of safety aids or Personnel Protective Equipment (PPE) are used for you own safety.

Environmental Management Policy for Service Manuals and Duets.

Product Support and Installation Contractors

Foster Refrigerator recognises that its activities, products and services can have an adverse impact upon the environment.

The organisation is committed to implementing systems and controls to manage, reduce and eliminate its adverse environmental impacts wherever possible, and has formulated an Environmental Policy outlining our core aims. A copy of the Environmental Policy is available to all contractors and suppliers upon request.

The organisation is committed to working with suppliers and contractors where their activities have the potential to impact upon the environment. To achieve the aims stated in the Environmental Policy we require that all suppliers and contractors operate in compliance with the law and are committed to best practice in environmental management.

Product Support and Installation contractors are required to:

1. Ensure that wherever possible waste is removed from the client's site, where arrangements are in place all waste should be returned to Foster Refrigerator's premises. In certain circumstances waste may be disposed of on the client's site; if permission is given, if the client has arrangements in place for the type of waste.
2. If arranging for the disposal of your waste, handle, store and dispose of it in such a way as to prevent its escape into the environment, harm to human health, and to ensure the compliance with the environmental law. Guidance is available from the Environment Agency on how to comply with the waste management 'duty of care'.
3. The following waste must be stored of separately from other wastes, as they are hazardous to the environment: refrigerants, polyurethane foam, and oils.
4. When arranging for disposal of waste, ensure a waste transfer note or consignment note is completed as appropriate. Ensure that all waste is correctly described on the waste note and include the appropriate six-digit code from the European Waste Catalogue. Your waste contractor or Foster can provide further information if necessary.
5. Ensure that all waste is removed by a registered waste carrier, a carrier in possession of a waste management licence, or a carrier holding an appropriate exemption. Ensure the person receiving the waste at its ultimate destination is in receipt of a waste management licence or valid exemption.
6. Handle and store refrigerants in such a way as to prevent their emission to atmosphere, and ensure they are disposed of safely and in accordance with environmental law.
7. Make arrangements to ensure all staff who handle refrigerants do so at a level of competence consistent with the City Guilds 2078 Handling Refrigerants qualification or equivalent qualification.
8. Ensure all liquid substances are securely stored to prevent leaks and spill, and are **not** disposed of to storm drains, foul drain, or surface water to soil.

Disposal Requirements

If not disposed of properly all refrigerators have components that can be harmful to the environment. All old refrigerators must be disposed of by appropriately registered and licensed waste contractors, and in accordance with national laws and regulations.

Foster Prep Station Descriptions

The range consists of 2 to 5 door models with a storage capacity ranging from 270 to 720 litres. The cabinets are manufactured as a one piece foam shell with easy clean stainless steel exterior. All conform to current legislation and exceed the Montreal protocol using zero ODP refrigerants and insulation. The temperature is controlled by a LAE microprocessor control with digital temperature display. Easy accessible condensing unit fitted at the rear for ease of servicing. The standard refrigeration system is integral with an air-cooled condensing unit with the refrigerant distribution into the evaporator controlled by capillary. The cooled air is circulated through the evaporator, via the fan into the storage area. Coated coils prevent corrosion and prolong refrigeration life. Easy to read temperature display with wipe clean finish. Wide magnetic gasket giving a positive door seal.

Temperature and Capacities

Model	FPS 2HR	FPS 3HR	FPS 4HR	FPS 5HR
Counter Base Storage Temperature	+1 to +4°C	+1 to +4°C	+1 to +4°C	+1 to +4°C
Pan Storage Temperature (with Lids Fitted)	+3 to +5°C	+3 to +5°C	+3 to +5°C	+3 to +5°C
Nett Capacity (litres)	270	420	570	720
Pan Clear Opening	1058 x 305	1640 x 305	2222 x 305	2804 x 305
Max Number of 1/3 Pans per Opening	6	9	12	16
Door Opening (w x h) Per Door	450 x 604	450 x 604	450 x 604	450 x 604
Door Opening Depth	1345	1345	1345	1345
Shelf Size	417 x 410	417 x 410	417 x 410	417 x 410
Number of Shelves Supplied Per Unit	4	6	8	10
Number OF Castors Supplied	5	5	5	6

Controller Relavance Table

Model	1 st Serial Number Issued	Manufacturer Date from
Counter	E5269275	05.07.2010

Controller Operation

FD2-10 Controller (00-556241)
 Probe Evap 2.5M SN4K15H2 (00-556251)
 Probe Air 2.5M SN4K15H1 (00-556248)
 LCD 5S Display (00-555992)

LCD5 Connecting Ribbon 1.5m (00-555741)
 LCD5 Connecting Ribbon 3m (00-555814)
 (Normally only used on FPS4 & 5'S Models)



LCD 5S Display (00-555992)

Indicators and Buttons

Symbol	Reason	Button	Use
	Alarm		Info / Set Point Button
	Thermostat Output		Manual Defrost / Decrease Button
	Fan Output		Increase Button / Manual Activation
	Defrost Output		Stand-by Button
	Activation of 2 nd parameter set		

Display

During normal operation the display shows either the temperature measured or one of the following indicators:

Symbol	Reason	Symbol	Reason
dEF	Defrost in progress	hP	Condenser high pressure alarm
aFF	Controller in stand-by	h ₁	Room high temperature alarm
cL	Condenser clean warning	Lo	Room low temperature alarm
do	Door open alarm	E1	Probe T1 failure
hc	Condenser high temperature alarm	E2	Probe T2 failure

Information Menu

The information available in the menu is shown below:

Symbol	Reason	Symbol	Reason
t1	Instant probe 1 temperature	tLo	Minimum probe 1 temperature recorded
t2	Instant probe 2 temperature *	cnD	Compressor working weeks **
t3	Instant probe 3 temperature *	Loc	Keypad state lock
th ₁	Maximum probe 1 temperature recorded		

* Displayed only if enabled (see configuration parameters)

** Displayed only if ACC > 0

User Functions

Start Sequence

For normal operation

- Press and hold the  button for 3 seconds then release.

If pressed and held for 5 seconds then released this will start the 'Test Sequence'.





The test function is a defined sequence of events that will follow a prescribed pattern (dependent upon parameter values). In turn it will operate all electrical elements of the system, simulating a short operating pattern. This was designed to provide a quick and simple evaluation tool to use either during manufacturing or when servicing.

To cancel the Test Sequence





- Press and release the  button during the test sequence.

If not pressed the test will continue and when complete the controller will wait for 1 min, then resume normal operation. (The controller will count to 530 then show 'end'. It will then show the current unit temperature)





Access to the menu and information displayed

- Press and immediately release button 
- With button  or  select the data to be displayed
- Press button  to display the value
- To exit from the menu, press button  or wait for 10 seconds.



Set point: Display and modification

- Press button  for at least half a second to display the set point.
- By keeping button  pressed, use button  or  to set the desired value (adjustment is within the minimum SPL and the maximum SPH limit)
- When button  is released, the new value is stored.

Reset of THI, TLO, CND recordings

- With button  or  select the data to be reset
- Display the value with button 
- While keeping button  pressed, use button .

Standby

When pressing the  button for 3 seconds, will allow the controller to be put on a standby or output control to be resumed (with SB = YES only). When on Standby  will be displayed.

Selection of second parameter group

It is possible to select control parameters between two different pre-programmed groups, in order for the fundamental control parameters to be adapted to changing needs. Changeover from Group I to Group II (and visa versa) may take place **Manually** by pressing  for 2 seconds (with IISM = MAN), or **Automatically** when heavy duty conditions are detected (with IISM = HDD), or when IISM =D12 and the **Auxiliary Input D12** is activated (the activation of D12 selects Group II). If IISM = NON, switchover to Group II is inhibited. The activation of Group II is signalled by the lighting up of relevant LED on the controller display.

Defrost

Automatic Defrost.

Defrost starts automatically as soon as the time set with parameter DFT has elapsed.

- **Time Defrost** With DFM = TIM defrost takes place at regular intervals when the timer reaches the value DFT. For example, with DFM = TIM and DFT = 06, a defrost will take place every 6 hours.
- **Defrost time count backup** At the power-up, if DFB = YES, the defrost timer resumes the time count from where it was left off before the power interruption. Visa versa with DFB=NO, the time count re-starts from 0. In stand-by the accumulated time count is frozen.

Defrost type

Once defrost has started, compressor and defrost outputs are controlled according to parameter DTY. If FID =YES, the evaporator fans are active during defrost.

Resuming Thermostatic Cycle

When defrost is over, if DRN is greater then 0, all outputs will remain off the DRN minutes, in order for the ice to melt completely and the resulting water to drain.

Manual Defrost

To initiate a manual defrost press and hold the defrost button  for 2 seconds.

Fuzzy Logic.

This setting is not available with any of these units.

Parameter Setting Wiring Diagram for Synchronising Defrost Start and Termination

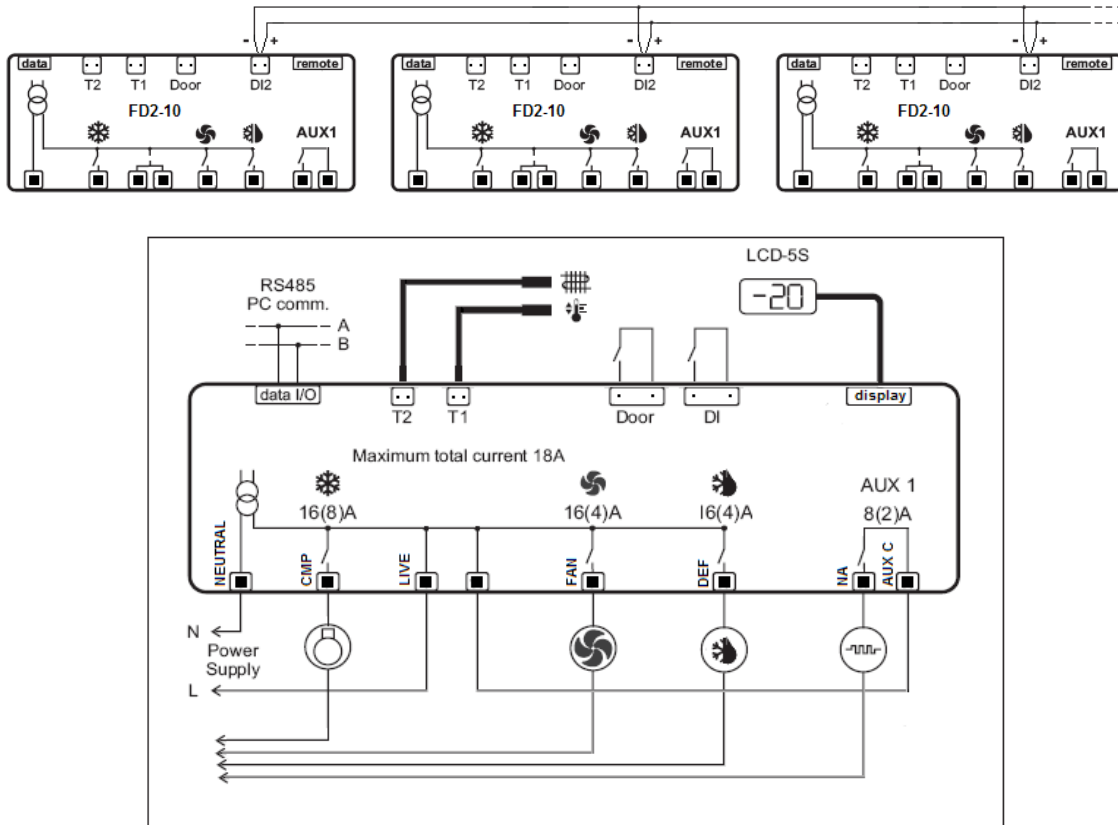

Technical Data

Power Supply

FD2-10 230Vac±10%, 50/60Hz, 3W

Relay Output

Compressor 16(8) A 240Vac
 Defrost 16(4) A 240Vac
 Evap. Fan 16(4) A 240Vac
 Auxiliary Loads 1 8(2) A 240Vac

Input

NTC 10KΩ@25°C

Measurement Range

-50...120°C, -55...240°F
 -50 / -9.9...19.9 / 80°C (NTC 10K Only)

Measurement Accuracy

<0.5°C within the measurement range

CE (Reference norms)

EN60730-1; EN60730-2-9
 EN55022 (Class B)
 EN50082-1

Configuration Parameters

- To get access to the parameter configuration menu, press + for 5 seconds
- With button or select the parameter to be modified.
- Press button and hold briefly to display the value. On releasing the button the controller will then show the next parameter.
- By keeping button pressed, use button or to set the desired value. On releasing the button the controller will store the amended value and then show the next parameter.
- To exit from the setup, press button or wait for 30 seconds.

FPS Controller Default Parameter Values

Parameter	Range	Description	Default FD2-10
SCL		Readout Scale:	2°C
	1°C	Range -50/-9.9.... 19.9/80°C (With INP = SN4 Only)	
	2°C	Range -50 120°C	
	°F	Range -55 240°F	
SPL	-50 ... SPH	Minimum Limit for SP setting	1
SPH	SPL ...120°	Maximum limit for SP setting	3
SP	SPL ... SPH	Temperature set point to be achieved	2
C-H		Temperature Control mode:	REF
	REF	Refrigeration	
	HEA	Heating	
HYS	1 ... 10°	Off/On Thermostat differential	3
CRT	0 ... 30min	Compressor Rest Time	2
CT1	0 ... 30min	Thermostat run time with faulty T1 probe. (CT1 = 0 output with faulty T1 will always be off)	6
CT2	0 ... 30min	Thermostat off time with faulty T1 probe. (CT2=0 & CT1 = >0 output with faulty T1 will always be on)	4
CSD	0 ... 30min	Compressor stop delay after door has been opened (Only if DS = YES)	1
DFM		Defrost Start Mode:	TIM
	Non	Defrost function is disabled	
	TIM	Regular time defrost	
	FRO	Defrost time elapses only in condition of frost accumulation	
DFT	0...99 Hours	Time interval between defrosts	6
DFB		Defrost timer clock	YES
	YES	Following mains interruption, timer resumes count	
	NO	Following mains interruption, timer restarts from zero	
DLI	-50.. 120°	Defrost end temperature (Only if T2 = EPO)	N/A
DTO	1 ... 120min	Maximum defrost duration	20
DTY		Defrost Type:	OFF
	OFF	Timed off cycle defrost (compressor and heater off)	
	ELE	Electric heater defrost (compressor off, heater on)	
	GAS	Hot gas defrost (compressor and heater on)	
DPD	0 ... 240 sec	Evaporator pump down. Timed pause at start of defrost	0
DRN	0 ... 30min	Drain down period	2
DDM		Defrost display mode:	DEF
	RT	Real (actual) air temperature	
	LT	Last temperature display before start of defrost	
	SP	The current set point value.	
	DEF	"DEF"	

DDY	0... 60 min	Defrost display delay period Time DDM is shown following defrost termination	10
FID	Fans in defrost:		YES
	YES	Fans run during defrost	
	NO	Fans do not run during defrost	
FDD	-50 ... 120°	Evaporator fan restart temperature following defrost (Only if T2 = EPO)	5
FTO	0... 120 min	Maximum evaporator fan stop period following defrost	3
FDS	0... 120 sec	Minimum evaporator fan stops (following door opening etc)	20
FCM	Evaporator fan mode during thermostatic control:		TIM
	NON	Fan(s) run continuously	
	TMP	Temperature based control. When compressor is on, fans are on. When compressor is off, fans run as long as temperature difference $T_e - T_a > FDT$. Fans on again with FDH	
	Tim	Time based control. When compressor is on, fans are on. When compressor is off, fans in accordance to parameters FT1, FT2 and FT3.	
FDT	-120 ... 0°	$T_e - T_a$ difference for fans to turn off after compressor stopped. (Only if T2 = EPO and FCM = TMP)	-1
FDH	1 ... 120°	Temperature differential for evaporator fan restart. (Only if T2 = EPO and FCM = TMP)	3
FT1	0 ... 180 Sec	Fan stop delay after compressor stop.	15
FT2	0 ... 30min	Timed fan stop following FT1 (With FT2 = 0 the fans remain on all the time).	3
FT3	0 .. 30min	Timed fan run following FT2 (With FT3 = 0 and FT2 >0 the fans remain off all the time).	2
ATM	Alarm threshold configuration:		REL
	NON	All temperature alarms are inhibited	
	ABS	The value set in ALA and AHA represent actual alarm set points	
	REL	The values set in ALR and AHR are alarm differentials which relate to SP and SP + HYS	
ALA	-50 ... 120°	Low temperature alarm threshold	
AHA	-50 ... 120°	High temperature alarm threshold	
ALR	-12 ... 0°	Low temperature alarm differential (With ALR = 0 the low temperature alarm is excluded)	-5
AHR	0 ... 12°	High temperature alarm differential (With AHR = 0 the low temperature alarm is excluded)	5
ATI	Alarm probe:		T1
	T1	Air temperature probe used for alarm detection	
	T2	Evaporator temperature probe used for alarm detection	
ATD	0... 120min	Delay before alarm temperature warning	90
ADO	0... 30min	Delay before door open alarm warning	8

AHM		Operation in case of high condenser alarm (T2 = CND)	NON
	NON	High condenser temperature alarm inhibited	
	ALR	Condenser warning – ‘HC’ displayed, alarm sounds	
	STP	As ‘ALR’ with compressor stopped and defrosts suspended	
AHT	-50 ... 120°	Condenser alarm temperature (T2 = CND)	65
ACC	0...52 Weeks	Condenser cleaning period. (With ACC = 0 condenser cleaning is disabled)	0
IISM		Switchover method to second parameter set:	HDD
	NON	Second parameter set is excluded	
	MAN	Second parameter set is activated/ deactivated by button II°	
	HDD	Second parameter activated by ‘heavy’ usage	
IISL	-50 . IISH	Minimum limit for IISP setting	1
IISH	IISL .. 120°	Maximum limit for IISP setting	1
IISP	IISP...IISH	Temperature set point to be achieved in ‘Mode 2’	1
IIHY	1 ... 10°	Off/on thermostat differential in ‘Mode 2’	3
IIFC		Evaporator fan mode during ‘Mode 2’ thermostatic control:	NON
	NON	Fans(s) run continuously	
	TMP	Temperature based control. When compressor is on, fans are on. When compressor is off, fans run as long as temperature difference $T_e - T_a > FDT$. Fans on again with FDH	
	TIM	Time based control. When compressor is on, fans are on. When compressor is off, fans in accordance to parameters FT1, FT2 and FT3.	
HDS	1 ... 5	Controller sensitivity for switch over between ‘Modes’ and 2. (1 = minimum, 5 = maximum)	3
IIDF	0 ... 99hours	Time interval between defrosts in ‘Mode 2’.	6
SB		Standby button operation:	YES
	YES	Standby button enabled	
	No	Standby button disabled	
DS		Door switch operation (switch made when door closed):	YES
	YES	Door switch enabled	
	NO	Door switch disabled	
DI2		Configuration digital input operation:	NON
	NON	Digital input 2 not activated	
	HPS	High pressure alarm when contact opens	
	IISM	‘Mode 2’ parameters active when contact closes	
	RDS	Defrost initiated when contact closes	
	DS2	Second door switch function (operated ‘in series’ with DS)	
LSM		Light control mode:	NON
	NON	Digital input 2 not activated	
	MAN	Light output operation is activated/deactivated by button II° (With OA1 = LGT)	
	DOR	Light output is switched on when door is opened (With OA1 = LGT and DS = YES)	
	NDR	Light output is switched off when door is opened. (With OA1 = LGT and DS = YES)	

OA1		Auxiliary relay operation:	NON
	NON	Output disabled (always off)	
	0-1	Contacts open/close with standby/on mode	
	LGT	Output enabled for light control	
	AL0	Contacts open when an alarm condition occurs	
	AL1	Contacts close when an alarm condition occurs (Relay contacts open when in standby mode)	
INP		Temperature sensor(s) type:	SN4
	SN4	10k NTC type thermistor (red writing)	
	ST1	1k PTC type thermistor (Black Writing)	
OS1	-12.5...12.5°C	Air temperature probe (T1) offset.	0
T2		T2 Probe function:	NON
	NON	T2 Probe disabled	
	EPO	Evaporator temperature monitoring	
	CND	Condenser temperature monitoring	
OS2	-12.5...12.5°C	T2 probe temperature offset	0
TLD	1 ... 30min	Delay for min (TLO) and max. (THI) temperature logging	10
SIM	0 ... 100	Display Slowdown	5
ADR	1... 255	FD2-10 address for PC communication	1

Cabinet General Arrangement

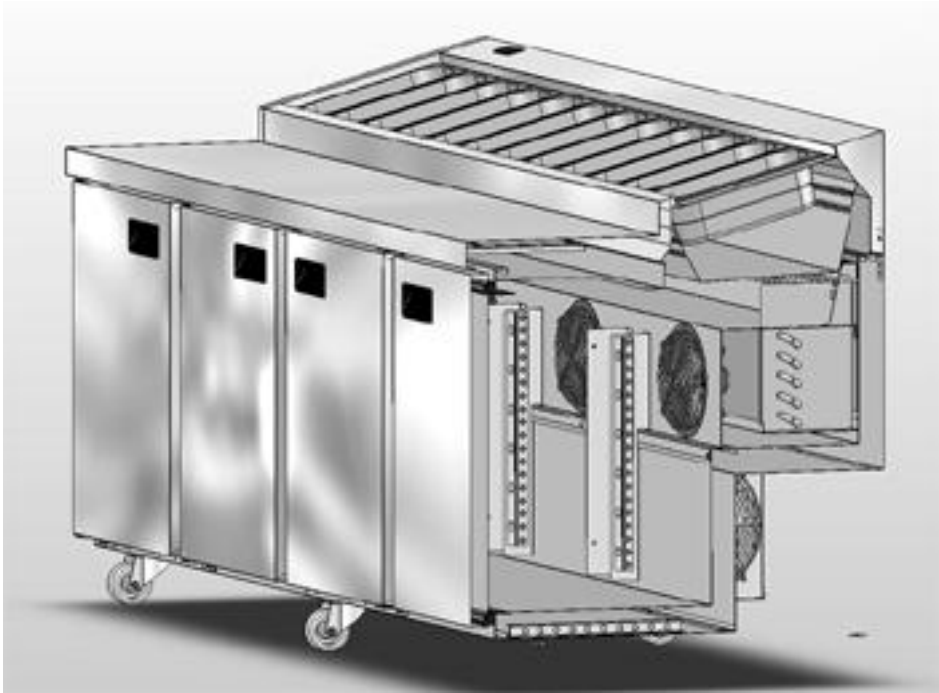

Evaporator Assembly

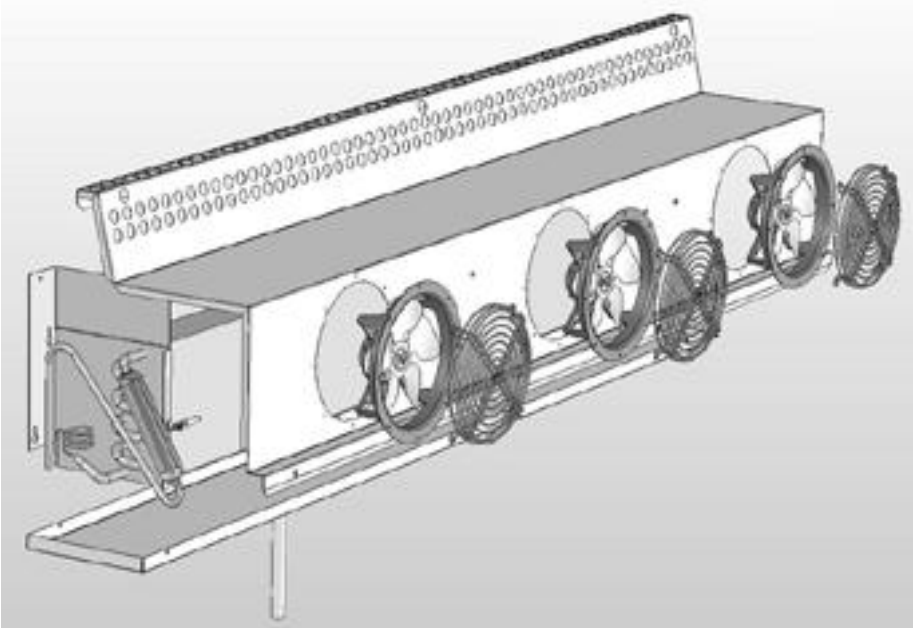

FPS2HR & FPS3HR Condensing Unit Arrangement.

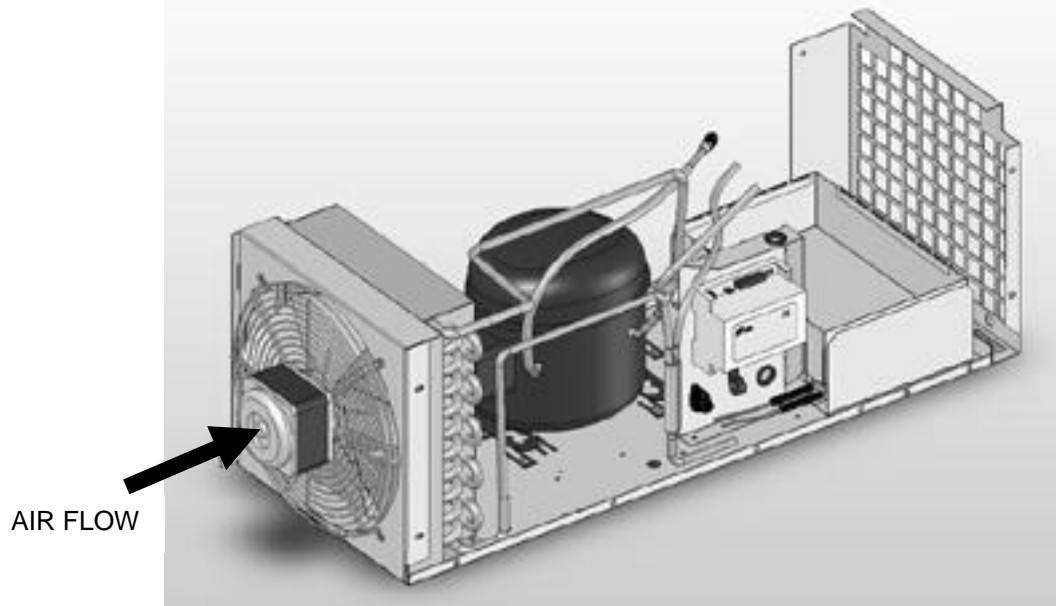

FPS4HR & FPS5HR Condensing Unit Arrangement.

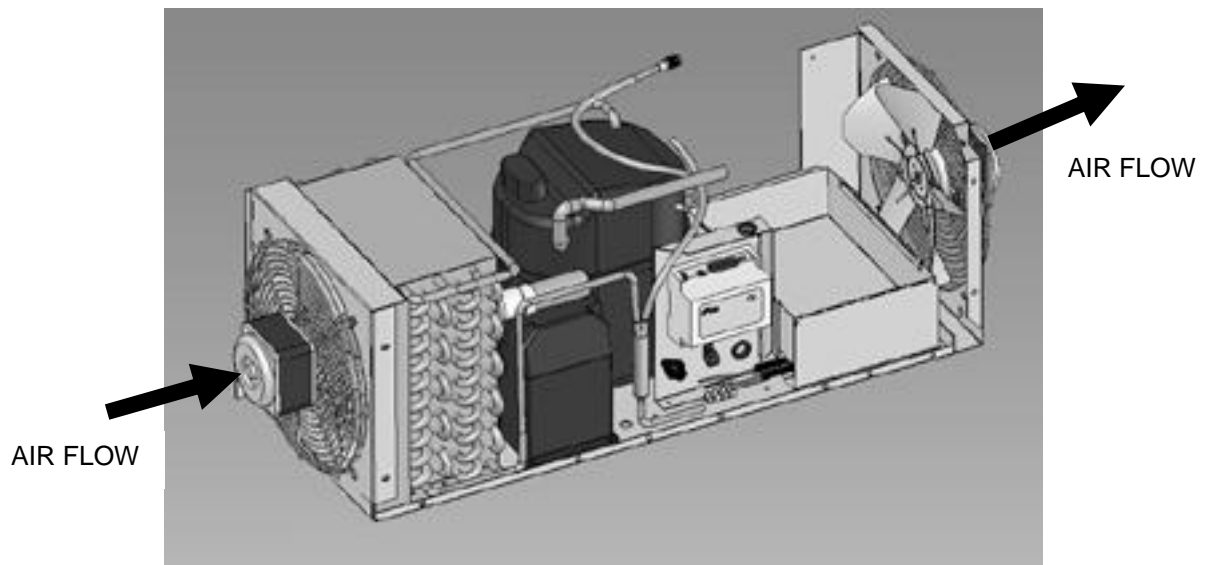

Technical Data Foster Prep Stations

Model	Storage Temp	Gas	Gas Charge	Compressor	Capillary	Defrost Type	Voltage	Power Consumption		Thermal Heat Rejection	Net Weight Kgs	Fuse Rating
								Watts	Amps			
FPS2HR	+3°C to +5°C	R134A	375 grms	SC12GX	3.0m x 0.042	Timed Off Cycle	230/50/1	690	4.4	1050	164	13 Amp
FPS3HR	+3°C to +5°C	R134A	460 grms	SC15GX	3.0m x 0.054	Timed Off Cycle	230/50/1	875	5.6	1620	207	13 Amp
FPS4HR	+3°C to +5°C	R134A	575 grms	CAJ4492Y	3.0m x 0.064	Timed Off Cycle	230/50/1	1140	7.4	2240	245	13 Amp
FPS5HR	+3°C to +5°C	R134A	800 grms	CAJ4492Y	3.0m x 0.064	Timed Off Cycle	230/50/1	1170	7.6	2280	265	13 Amp

FOSTER FD2-10						FPS2HR	FPS3HR	FPS4HR	FPS5HR
Reg	Par	Min	Mid	Max	Description	C	C	C	C
253	SCL	1°C	°F	2°C	Readout scale.	2°C	2°C	2°C	2°C
200	SPL	-50°	SPH	Minimum limit for SP setting.	1	1	1	1
202	SPH	SPL	120°	Maximum limit for SP setting.	3	3	3	3
204	SP	SPL	SPH	Temperature setpoint to be achieved.	1	1	1	1
268.1	C-H	REF	HEA	Temperature control mode.	REF	REF	REF	REF
214	HYS	1°	10°	Off / On thermostat differential.	4	4	4	4
216	CRT	0 min	30 min	Compressor rest time.	2	2	2	2
217	CT1	0 min	30 min	Thermostat run time with faulty T1 probe.	6	6	6	6
218	CT2	0 min	30 min	Thermostat off time with faulty T1 probe.	4	4	4	4
219	CSD	0 min	30 min	Compressor stop delay after door has been opened. (Only if DS = YES).	1	1	1	1
220	DFM	NON	FRO	TIM	Defrost start mode.	TIM	TIM	TIM	TIM
221	DFT	0 hours	99 hours	Time interval between defrosts.	6	6	6	6
268.4	DFB	NO	YES	Defrost timer clock.	YES	YES	YES	YES
206	DLI	-50°	120°	Defrost end temperature (Only if T2 = EPO).	20	20	20	20
223	DTO	1 min	120 min	Maximum defrost duration.	20	20	20	20
224	DTY	OFF	ELE	GAS	Defrost type.	OFF	OFF	OFF	OFF
225	DPD	0 sec	240 sec	Evaporator pump down. Timed pause at start of defrost.	0	0	0	0
226	DRN	0 min	30 min	Drain down period.	2	2	2	2
227	DDM	RT	SP, DEF	LT	Defrost display mode.	DEF	DEF	DEF	DEF
228	DDY	0 min	60 min	Defrost display delay period.	10	10	10	10
267.5	FID	NO	YES	Fans in defrost.	YES	YES	YES	YES
207	FDD	-50°	120°	Evaporator fan restart temperature following defrost. (Only if T2 = EPO).	5	5	5	5
229	FTO	0 min	120 min	Maximum evaporator fan stop period following defrost.	3	3	3	3

237	FDS	0 sec	120 sec	Minimum evaporator fan stop (following door opening etc.).	20	20	20	20
230	FCM	NON	TIM	TMP	Evaporator fan mode during thermostatic control.	TIM	TIM	TIM	TIM
232	FDT	-120°	0°	Te-Ta difference for fans to turn off after compressor stopped. (Only if T2 = EPO and FCM = TMP).	-1	-1	-1	-1
233	FDH	1°	120°	Temperature differential for evaporator fan restart. (Only if T2 = EPO and FCM = TMP).	3	3	3	3
234	FT1	0 sec	180 sec	Fan stop delay after compressor stop.	15	15	15	15
235	FT2	0 min	30 min	Timed fan stop following FT1. (With FT2 = 0 the fans remain on all the time).	0	0	0	0
236	FT3	0 min	30 min	Timed fan run following FT2. (With FT3 = 0 & FT2 > 0 the fans remain off all the time).	2	2	2	2
238	ATM	NON	REL	ABS	Alarm threshold configuration.	REL	REL	REL	REL
208	ALA	-50°	120°	Low temperature alarm threshold.	-2	-2	-2	-2
209	AHA	-50°	120°	High temperature alarm threshold.	8	8	8	8
239	ALR	-12°	0°	Low temperature alarm differential. (With ALR = 0 the low temperature alarm is excluded).	-5	-5	-5	-5
240	AHR	0°	12°	High temperature alarm differential. (With AHR = 0 the low temperature alarm is excluded).	5	5	5	5
241	ATI	T1	T2	Alarm probe.	T1	T1	T1	T1
242	ATD	0 min	120 min	Delay before alarm temperature warning.	90	90	90	90
243	ADO	0 min	30 min	Delay before door open alarm warning.	8	8	8	8
244	AHM	NON	STP	ALR	Operation in case of high condenser alarm (T2 = CND).	NON	NON	NON	NON
210	AHT	-50°	120°	Condenser alarm temperature (T2 = CND).	65	65	65	65
245	ACC	0 weeks	52 weeks	Condenser cleaning period. (With ACC = 0 condenser cleaning is disabled).	0	0	0	0
247	IISM	NON	HDD, DI2	MAN	Switchover method to second parameter set.	HDD	HDD	HDD	HDD
201	IISL	-50°	IISH	Minimum limit for IISP setting.	1	1	1	1
203	IISH	IISL	120°	Maximum limit for IISP setting.	1	1	1	1
205	IISP	IISL	IISH	Temperature setpoint to be achieved in 'Mode 2'.	1	1	1	1
215	IIHY	1°	10°	Off / On thermostat differential in 'Mode 2'.	4	4	4	4
231	IIFC	NON	TIM	TMP	Evaporator fan mode during 'Mode 2' thermostatic control.	NON	NON	NON	NON

246	HDS	1	5	Controller sensitivity for switch over between 'Modes' 1 and 2. (1 = minimum, 5 = maximum).	3	3	3	3
222	IIDF	0 hours	99 hours	Time interval between defrosts in 'Mode 2'.	6	6	6	6
268.7	SB	NO	YES	Standby button operation.	YES	YES	YES	YES
268.0	DS	NO	YES	Door switch operation (switch made when door closed).	NO	NO	NO	NO
251	DI2	NON	IISM, RDS, DS2	HPS	Configurable digital input operation.	NON	NON	NON	NON
248	LSM	NON	DOR, NDR	MAN	Light control mode.	NON	NON	NON	NON
249	OA1	NON	LGT, AL0, AL1	0-1	Auxiliary relay operation.	0-1	0-1	0-1	0-1
268.2	INP	ST1	SN4	Temperature sensor(s) type.	SN4	SN4	SN4	SN4
256	OS1	- 12.5°C	12.5°C	Air temperature probe (T1) offset.	0	0	0	0
250	T2	NON	EVP	CND	T2 probe function.	NON	NON	NON	NON
251	OS2	- 12.5°C	12.5°C	T2 probe temperature offset.	0	0	0	0
252	TLD	1 min	30 min	Delay for min. (TLO) and max. (THI) temperature logging.	10	10	10	10
254	SIM	0	100	Display slowdown.	5	5	5	5
255	ADR	1	255	FD2-10 address for PC communication	1	1	1	1

Parameters ALA and AHA will not be visible when ATM is set at REL.
Parameters ALR and AHR will not be visible if ATM is changed to ABS.

Prep Station (Integral and Remote models) Wiring Diagram

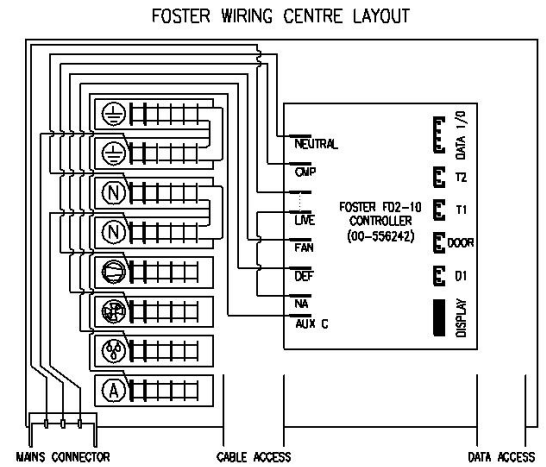
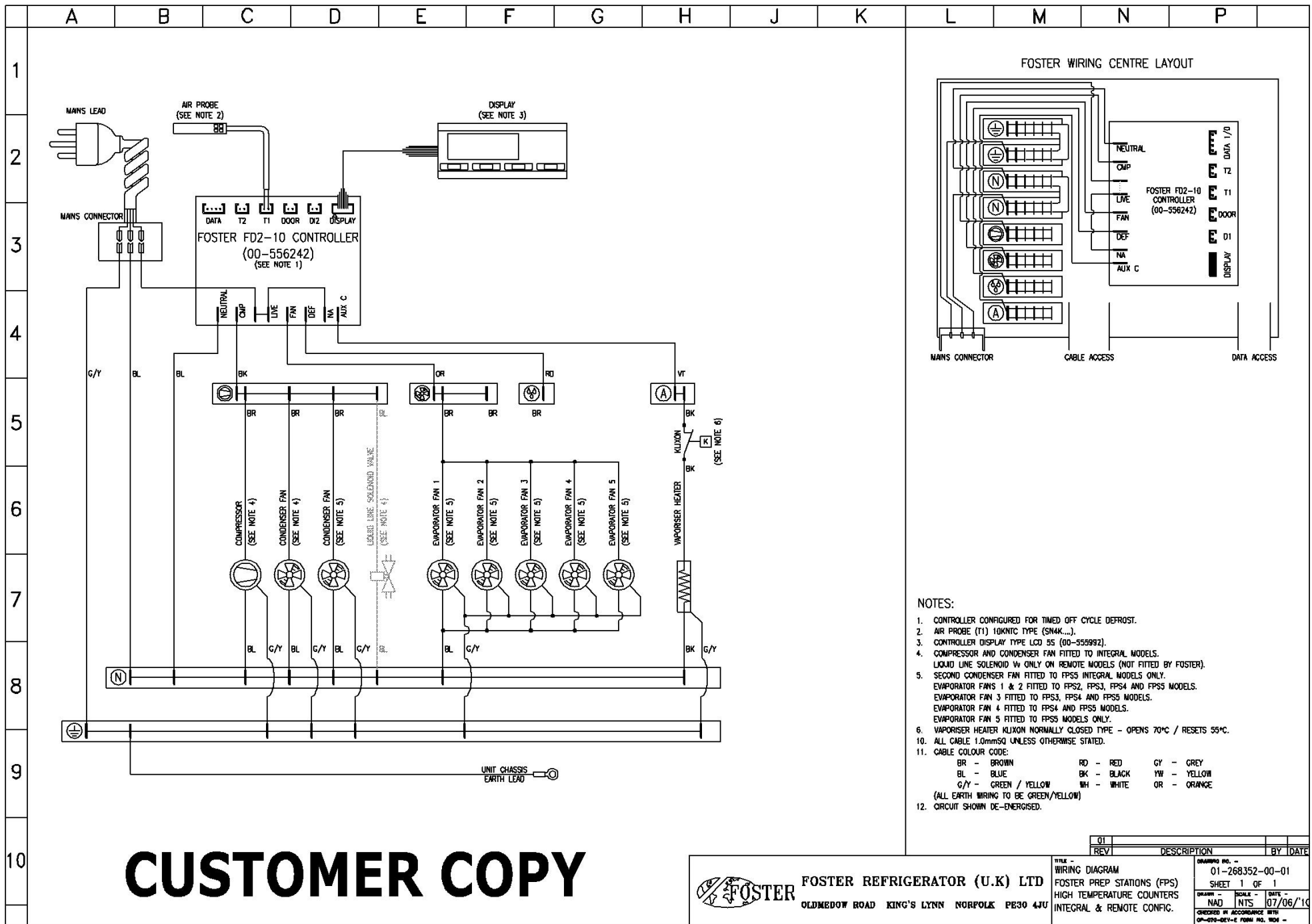

NOTES:

- CONTROLLER CONFIGURED FOR TIMED OFF CYCLE DEFROST.
- AIR PROBE (T1) 10KNTC TYPE (SN4K...).
- CONTROLLER DISPLAY TYPE LCD 5S (00-555992).
- COMPRESSOR AND CONDENSER FAN FITTED TO INTEGRAL MODELS. LIQUID LINE SOLENOID VALVE ONLY ON REMOTE MODELS (NOT FITTED BY FOSTER).
- SECOND CONDENSER FAN FITTED TO FPS2 INTEGRAL MODELS ONLY. EVAPORATOR FANS 1 & 2 FITTED TO FPS2, FPS3, FPS4 AND FPS5 MODELS. EVAPORATOR FAN 3 FITTED TO FPS3, FPS4 AND FPS5 MODELS. EVAPORATOR FAN 4 FITTED TO FPS4 AND FPS5 MODELS. EVAPORATOR FAN 5 FITTED TO FPS5 MODELS ONLY.
- VAPORISER HEATER KUXON NORMALLY CLOSED TYPE - OPENS 70°C / RESETS 55°C.
- ALL CABLE 1.0mm² UNLESS OTHERWISE STATED.
- CABLE COLOUR CODE:
 BR - BROWN RD - RED GY - GREY
 BL - BLUE BK - BLACK YW - YELLOW
 G/Y - GREEN / YELLOW WH - WHITE OR - ORANGE
 (ALL EARTH WIRING TO BE GREEN/YELLOW)
- CIRCUIT SHOWN DE-ENERGISED.

CUSTOMER COPY



FOSTER REFRIGERATOR (U.K) LTD
 OLDMEDDOW ROAD KING'S LYNN NORFOLK PE30 4JU





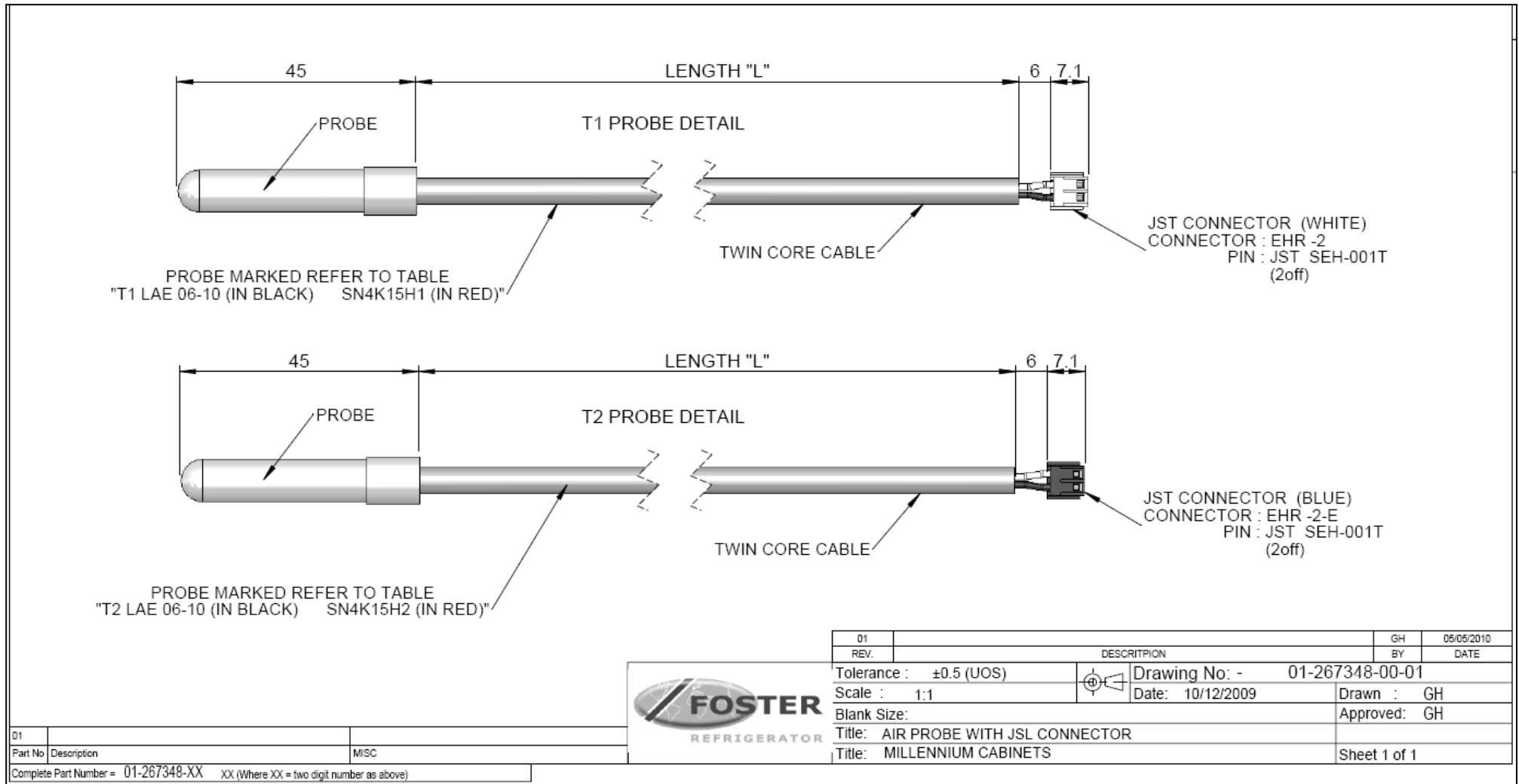





01			
REV	DESCRIPTION		BY / DATE
TITLE - WIRING DIAGRAM		DRAWING NO. - 01-268352-00-01	
FOSTER PREP STATIONS (FPS)		SHEET 1 OF 1	
HIGH TEMPERATURE COUNTERS		SCALE - NTS	
INTEGRAL & REMOTE CONFIG.		DATE - 07/06/10	
CHECKED IN ACCORDANCE WITH 01-070-021-2 FORM NO. 104 -			









Air and Evaporator Probe Details / Diagram



Probe Air 2.5M SN4K15H1 (00-556248)
Probe Evap 2.5M SN4K15H2 (00-556251)

Troubleshooting

Problem	Possible Cause	Solution
Compressor will not start	No voltage in socket	Use voltmeter to check
	Electrical conductor or wires may be cut	Use ohmmeter to check for continuity
	Defective electrical component: thermostat, relay, thermal protector etc	Replace defective component
	Compressor motor has a winding open or shorted	Measure ohmic resistance of main and auxiliary winding using ohmmeter. Compare with correct values
	Compressor stuck	Change compressor
	Temperature control contacts are open	Repair or replace the contacts
	Incorrect wiring	Check wiring diagram and correct
	Fuse blown or circuit breaker tripped.	Replace fuse or reset circuit breaker
	Power cord unplugged	Plug in power cord.
	Controller set too high	Set controller to lower temperature.
	Cabinet in defrost cycle	Wait for defrost cycle to finish
The temperature is too cold	Controller is set at a very cold position	Set to warmer position and check if the compressor stops according to controllers operating range.
	Controller does not disconnect the condensing unit	Check the insulation of the thermostat. If problem persists, change the thermostat
	Control contacts are stuck closed	Change the control. Check amperage load
	Defective or incorrect temperature control	Determine correct control and replace.
The temperature is not cold enough	Controller is set at a very warm position	Adjust to colder setting
	Condenser is dirty	Clean condenser
	The refrigerator has been placed at an inadequate location	The unit must not be near stoves, walls that are exposed to the sun, or places that lack sufficient air flow.
	Compressor is inefficient or there is a high pressure due to the air in the system	If there is air in the system, purge and recharge
 	Iced up evaporator coil	Check temperature control, refrigerant charge, and defrost mechanism. Remove all ice manually and start over.
	Restriction in system	Locate exact point of restriction and correct
	The refrigerator has been used improperly	The shelves must never be covered with any type of plastic or other material that will block the circulation of cold air within the refrigerator.
	Too many door openings	Advise user to decrease if possible
	Excessive heat load placed in cabinet	Advise user not to put in products that are too hot.
	The refrigerator has been overcharged with the refrigerant gas	Check to see if condensation or ice crystals have formed on the suction line. If so, charge with the correct amount of gas.

		The refrigerant gas is leaking	Find the location of gas leak in order to seal and replace the defective component. Change the drier. Perform a good vacuum and recharge unit.
		The evaporator and/or condenser fans are not working	Check electrical connections and make sure that the fan blade isn't stuck. Replace the fan motor if it doesn't work.
		Blocking air flow	Re-arrange product to allow for proper air flow. Make sure there is at least four inches of clearance from evaporator.
		Fuse blown or circuit breaker tripped	Replace fuse or reset circuit breaker.
Electrical Shocks		Wires or electrical components are in direct contact with metallic parts.	Check for appropriate insulation on the connections of each component.
Noise		The refrigerator is not properly levelled	Check if the noise goes away after you level the refrigerator
		The condenser is not fastened correctly. Copper tubing is in contact with metal	While the compressor is working, check to see if metal parts are in contact with one another and/or if the screws that fasten the condenser are tightened.
		The evaporator and/or condenser fans are loose	Check if the fans are securely fastened. Also, check if the fan blades are loose, broken or crooked. If so, change the faulty blade.
		Compressor has an internal noise	If the noise persists after all other measures have been taken, it may be originating from the compressor.
		Loose part(s)	Locate and tighten loose part(s)
Extreme condensation inside the refrigerator		Controller is set at a very cold position	Set the controller to a warmer position & check to see if compressor stops as should.
		The outside environment's relative humidity is very high (over 75%)	This type of occurrence is caused by local climatic conditions and not by the refrigeration unit.
		The refrigerator door wont shut completely	Check the door and/or the magnetic gasket. Adjust the door hinges if needed; replace the gasket if broken.
		The refrigerator had been placed at an inadequate location	The unit must not be near sources that produce too much heat.
No illumination (Glass door models only)		The light switch is "off" position	Press the light switch to "on" position
		False contact on the light switch, the fluorescent tube, or the ballast	Inspect all connections
		Light switch, ballast and/or fluorescent tube are damaged	Replace the damaged component.
Condensing unit runs for long periods of time		Excessive amount of warm product placed in cabinet	Advise user to leave adequate time for products to cool down
		Prolonged door opening or door ajar	Advise user to ensure doors are closed when not in use and to avoid opening doors for long periods of time.
		Door gasket(s) not sealing properly	Ensure gaskets are snapped in completely. Remove gasket and wash with soap and water. Check condition of gasket & replace if necessary



Dirty condenser coil

Clean condenser coil

Evaporator coil iced over

Unplug unit and allow coil to defrost. Make sure thermostat is not set too cold. Ensure that door gasket(s) are sealing properly. Select manual defrost and ensure system works.

Notes



Foster European Operations

France

Foster Refrigerator France SA

Tel: (33) 01 34 30 22 22. Fax: (33) 01 30 37 68 74.

Email: info@foster-fr.com

Germany

Foster Refrigerator Gmbh,

Tel: (49) 781 990 7840. Fax (49) 781 990 7844.

Email: info@foster-gmbh.de

Foster Refrigerator

Oldmedow Road

Kings Lynn

Norfolk

PE30 4JU

Tel: 0843 216 8833

Fax: 0843 216 4707

Website: www.fosterrefrigerator.co.uk

Email: support@foster-uk.com

a Division of 'ITW (UK) Ltd'

FPS COUNT/ FD2-10/SM 08/10