

FADPR2

**Foster, Automatic, Defrost,
Prove, Retard.
2 Trolley**

Installation and Operating Instruction Manual



ISO 14001



ISO 9001



DISPOSAL REQUIREMENTS

If not disposed of properly all refrigerators have components that can be harmful to the environment. All old refrigerators must be disposed of by appropriately registered and licensed waste contractors, and in accordance with national laws and regulations.

The materials used to package this refrigerator/coldroom may be recycled. Recycling will reduce the effect this waste has upon the environment. For information on waste collection facilities in your area, and other advice on recycling of packaging waste, visit www.recycle-more.co.uk

Environmental Management Policy for Installation Instructions.

Product Support and Installation Contractors

Foster Refrigerator recognises that its activities, products and services can have an adverse impact upon the environment.

The organisation is committed to implementing systems and controls to manage, reduce and eliminate its adverse environmental impacts wherever possible, and has formulated an Environmental Policy outlining our core aims. A copy of the Environmental Policy is available to all contractors and suppliers upon request.

The organisation is committed to working with suppliers and contractors where their activities have the potential to impact upon the environment. To achieve the aims stated in the Environmental Policy we require that all suppliers and contractors operate in compliance with the law and are committed to best practice in environmental management.

Product Support and Installation contractors are required to:

1. Ensure that wherever possible waste is removed from the client’s site, where arrangements are in place all waste should be returned to Foster Refrigerator’s premises. In certain circumstances waste may be disposed of on the clients site; if permission is given, if the client has arrangements in place for the type of waste.
2. If arranging for the disposal of your waste, handle, store and dispose of it in such a way as to prevent its escape into the environment, harm to human health, and to ensure the compliance with the environmental law. Guidance is available from the Environment Agency on how to comply with the waste management ‘duty of care’.

SECTION 1

INTRODUCTION

Foster, Automatic, Defrost, Prove, Retard. 2 Trolley

The pizza processing operation is provided in three formats:

1. Fully automatic process facility incorporating all three functions.
2. Manual Thaw/store facility.
3. Manual Prove/ Retard process facility.

The cabinet is designed to accommodate two special pizza trolleys.

The control system for each function displays time and temperature allowing the operator to determine the status of the process.

SECTION 2

CABINET SPECIFICATION

2.0 MODELS

2.1 Pizza Hut Modular Cabinet FADPR2.

Nomenclature based on - F = Foster. A = Automatic. D = Defrost. P = Prove R = Retard. 2 = trolleys.

2.2 Construction.

The product is of modular construction with the refrigeration system built onto an independent ceiling panel. The door is a slab type with self-closing rising butt hinges. Complete with a full height handle and no locks. Magnetic door gasket and a wiper gasket to the bottom edge of the door. The door can be hinged left or right hand as required.

Standard Finish.

Exterior walls.	Co-Laminate.
Rear Wall	Co-Laminate.
Front Wall.	Co-Laminate
Ceiling.	Co-Laminate
Door.	Stainless Steel 304.
Interior Walls & Ceiling.	Smooth Aluminium.

Insulation thickness CFC Free polyurethane foam.

Sides.	75mm
Back	75mm
Front	75mm
Ceiling	100mm
Door	50mm
Base	Floorless

2.3 Internal Fittings

Two Trolleys per section. (Not supplied as standard)

Maximum size of trolley 430 x 760 x 1730mm.

The internal walls are protected with aluminium Bumper Bars.

2.4 Service Requirements.

Electrical Supply 230V, 1 phase, 50Hz.

Fuse rating 13 Amp.

2.5 Temperature Ranges.

The cabinet is designed to automatically process Pizza Dough from a frozen condition (-18°C / -21°C) to a finished product as below.

Thaw/ Retard Temperature. +2°C/ +4°C.

Prove Temperature. +2°C/ +4°C to +28°C/ +32°C.

Retard Temperature. +28°C/ +32°C to +2°C/ +4°C.

The cabinet conforms to ISO Climate Class 5 (40°C ambient with 40% RH).

2.6 Control Function.

The machine uses the Foster Surf Navigation control system.

The controls are located in a control console mounted above the door.

2.7 Air Flow.

Air is circulated through the evaporator coil and discharged through a vented air duct fitted to the rear wall of the cabinet.

Internal airflow is generated by 3 x 10W motors with 200mm Ø, 34° pitch angle blades.

2.8 Retarding (Refrigeration).

The refrigeration system is a self-contained unit comprising air-cooled condensing unit, forced air evaporator and all ancillary parts and controls. The equipment is pre-charged with refrigerant and pre-wired to allow for easy installation on site.

Refrigerant used is R134a.

The evaporator has a large surface area to provide high humidity during the retard operation.

Refrigerant control is a capillary based system used to control the correct amount of refrigerant required to meet the demand of the evaporator.

2.9 Proving (Heating).

An electric heater assembly is mounted on the rear face of the cooling coil which is energised during the prove process.

As an extra safety feature, a pre-set overheat thermostat switch is provided should the main control thermostat fail.

During the Thaw process both cooling and heating are used to ensure that the air temperature is controlled to defrost the dough.

SECTION 3

INSTALLATION INSTRUCTIONS

Installation of these units should be carried out by a competent person and appropriate codes of practice adhered to thus ensuring safe installation.

3.1 REMOVAL OF THE PALLET.

The cabinets are of modular construction with the wall panels and ancillary items delivered with either shrink-wrap or wood case protective exterior. This exterior should be removed, which after cutting the band will allow all the components to be removed and then checked for damage before placement in a convenient area for assembly.

There could be more than one crate – so check each one as above.

3.2 INSTALLATION OF PANELS AND EQUIPMENT.

The following instruction is suggested as a method of installation.

Check the drawing of the modular cabinets to obtain the panel numbers.

The ceiling panel is supplied with the refrigeration system / heater assembly pre-fitted ready for installation once the wall panels are erected.

The cabinets are floorless and therefore require fitting to a clean level floor.

The wall panels are attached to the floor by inserting them into PVC 'U' Channel. This is supplied. cut and mitred and should be fitted to the floor prior to installation

3.3 Panel Layout and Dimensions

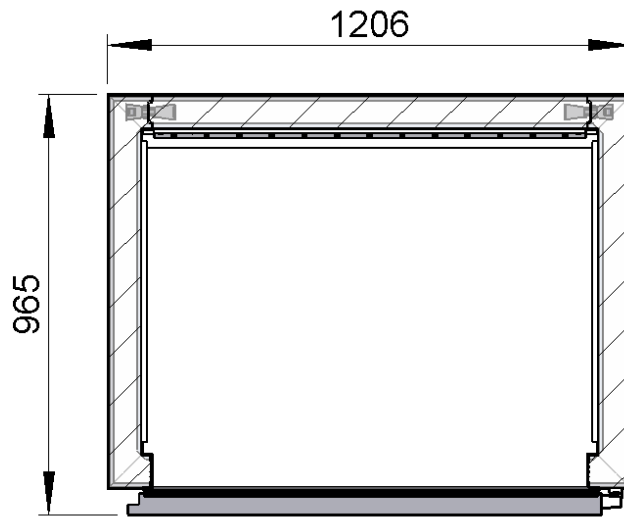

3.4 Ceiling panel with the refrigeration system / heater assembly

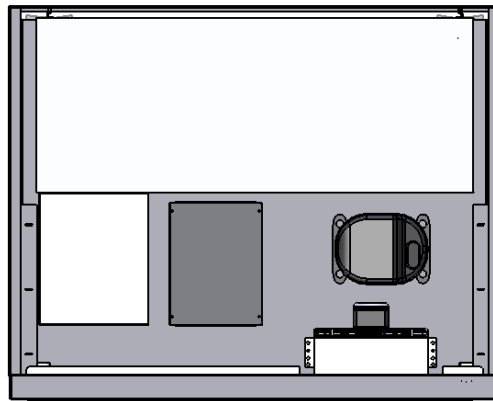

3.5 Cabinet Dimensions

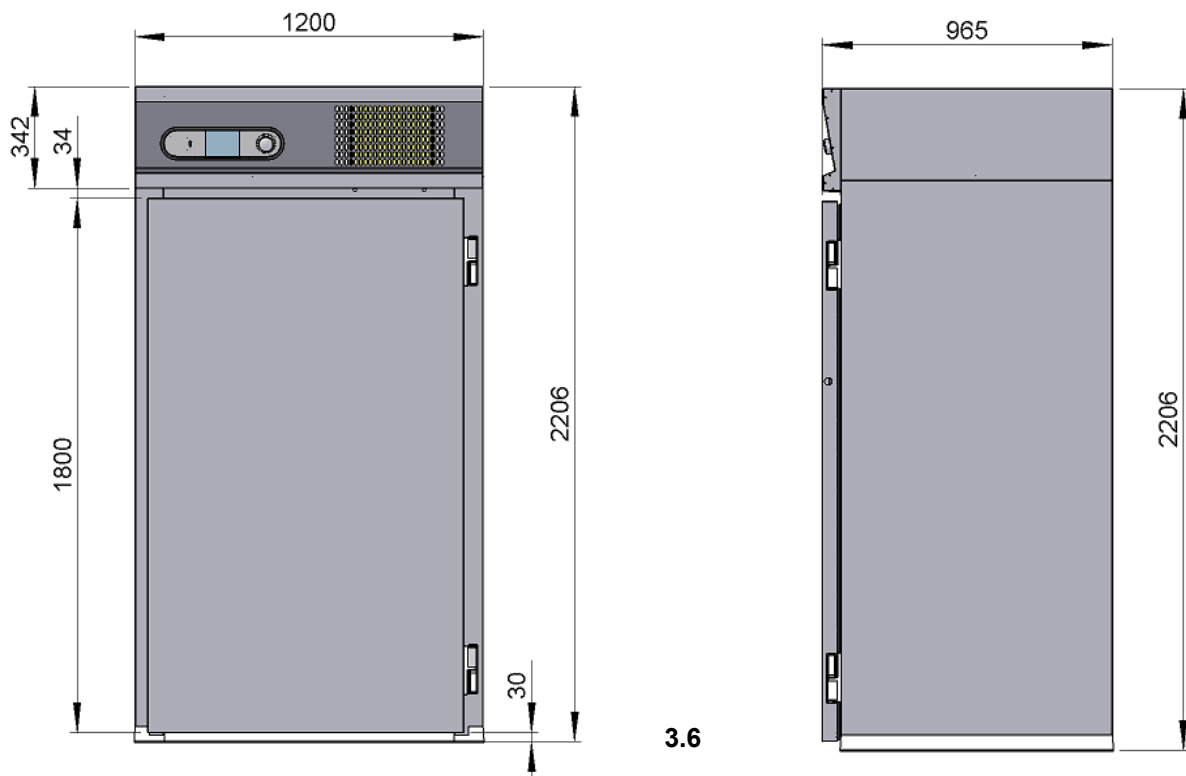

3.6

'U' Channel Fitting

The 'U' channel is supplied cut to the correct lengths, use the cardboard template provided to position the channel on the floor.

The external dimensions of the room are - 1200mm Wide X - 965mm Deep

It is important that the 'U' channel is fixed squarely so that the panels will lock together when inserted.



It is recommended that there should be no more than 3mm tolerance in the floor level as this can affect the correct location of the locking panels.

Using a spirit level check floor level on all four sides.

If required use packing shims to take up any anomalies in the floor.

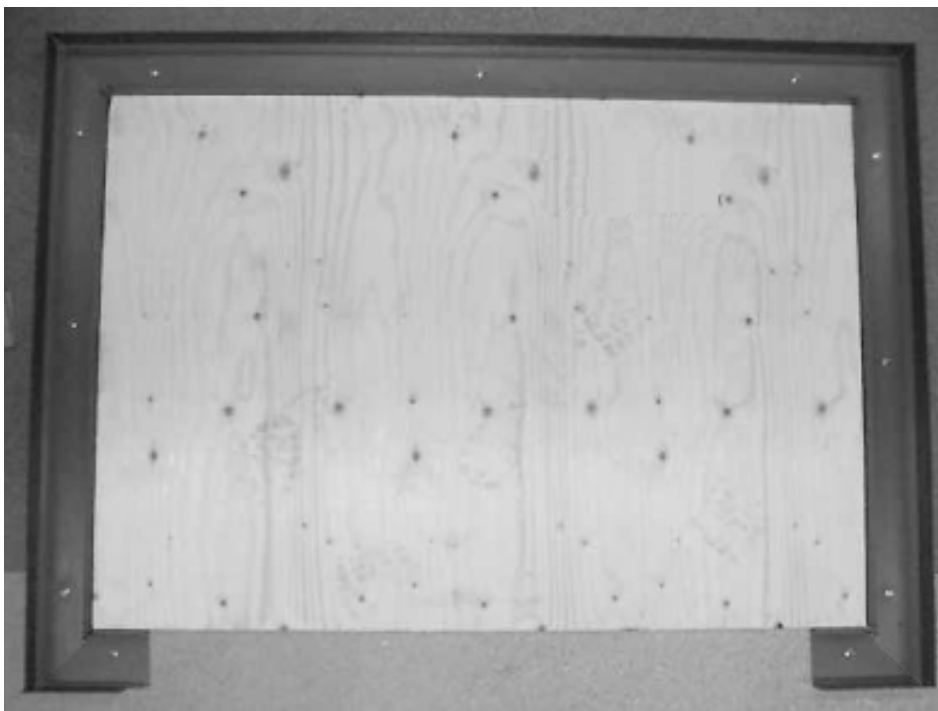

Once you are satisfied with the level the U channel can be rawl-plugged or hilti-nailed into position ensuring it is sealed with silicone sealer between the floor and the channel to prevent moisture penetration.

Apply 'mastic sealer' to the inside of the channel so that when the panels are located there is a vapour seal.

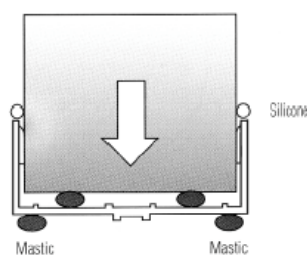

3.7 ASSEMBLY OF WALL PANELS.

Note: there is no door header panel as this is integral with the ceiling panel.
Fit the side panel into the channel and apply a bead of mastic to the rear edge to create a vapour seal rear (see fig 1). Place the rear panel in the channel, these can now be locked together by means of the Foster Lock (see fig 2) operated by the hexagon shaped key provided (see fig 3). All panels are locked internally.

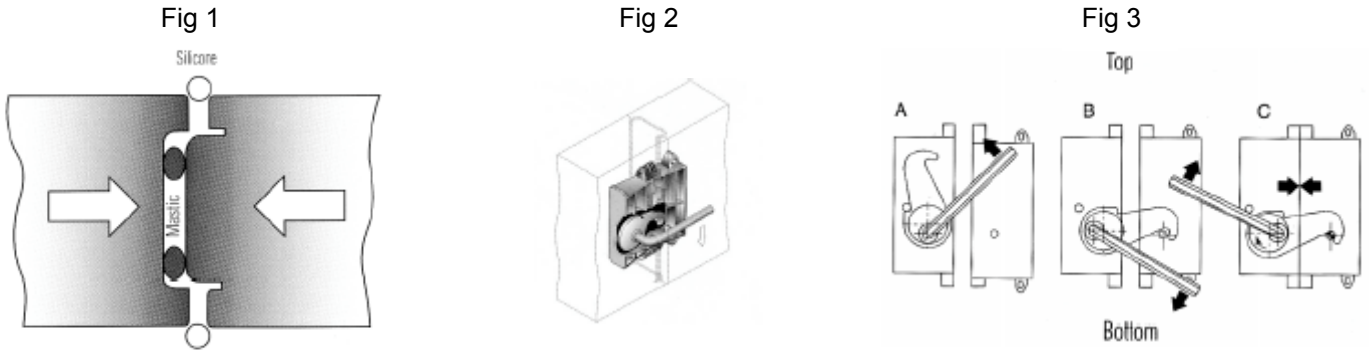

3.8 FITTING THE CEILING PANEL.

At the top of the wall panels there is a recess that accepts the ceiling panel.
Apply mastic to the recess so that when the panel is fitted there is a good vapour seal.

Slacken the screws securing the front panel to the sides and lift away, taking care not to damage the interconnecting cables, rest it securely on the top of the ceiling panel. See below.
Lift the ceiling panel complete and lower into the top recess.

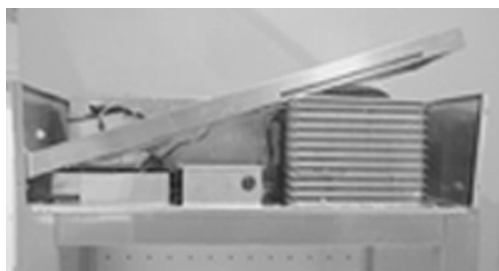

With the ceiling panel in place slide the galvanised angle bracket into place (see fig 4). Secure in place using the screws provided (see fig 5 and 6).

Fig 4



Fig 5



Fig 6



With the ceiling panel secured in place seal the internal joints with silicone sealer. Insert the buttons into the lock holes.

3.9 FITTING THE REAR AIR DUCT

- 1) Prior to fitting the rear air duct check that the **Air Return Duct (A)** is correctly located into the **Coil Dripray Flange (B)**, see fig 7.
- 2) Place the air duct against the rear of the cabinet and insert into the space between the air return duct and the rear of the cabinet to a depth of 10mm, see fig 7, secure in place using the self tapping screws provided.

Fig 7

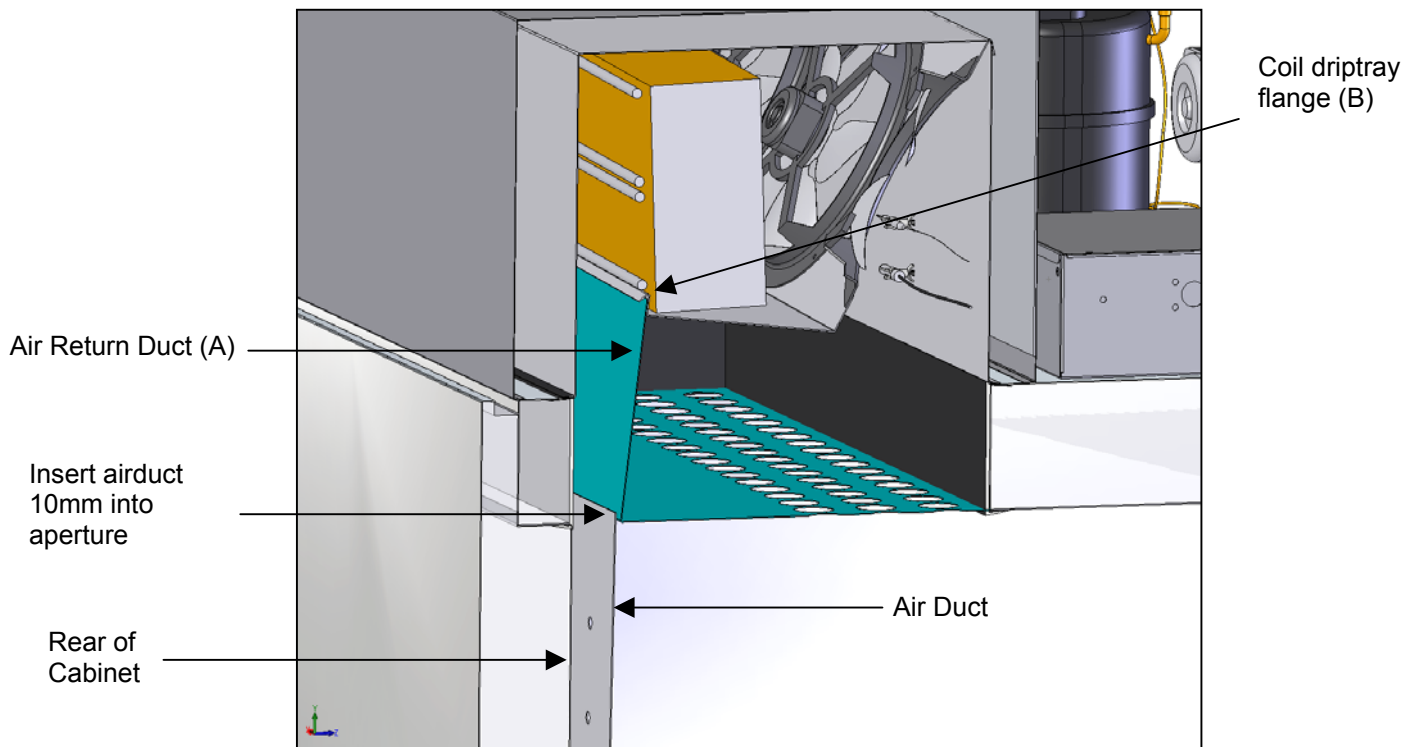

3.10 FITTING THE BUMPER BARS

Place the rear bumper bars against air duct and line up with the pre-drilled threaded holes in the duct, secure in place using the M5 screws provided. Place the side bumper bars against side panels lining them up with the pre-drilled holes, secure in place using the self tapping screws provided.

3.10 FITTING THE DOOR

Check that the inserts are fitted correctly into the hinge parts attached to the cabinet (see fig 8).
 Check that the insert for the door part of the hinges are correct for the door hinging, fig 9 shows the insert fitted for right hand hinging.

Fig 8



Fig 9

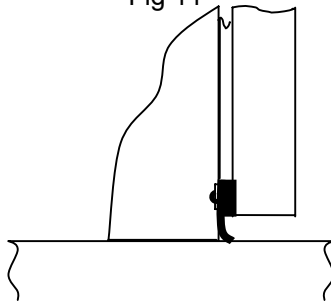

Fig 10



Hold the door at a 90° angle to the cabinet and lower the door on to the hinges, see fig 10 for the correct hinge alignment in the closed position. Check that it hangs squarely to the cabinet.
 Re-fit the unit cover and check that the top of the door lines up with the bottom of it.
 To remove the door reverse the process.
 After hanging the door inspect the door gasket ensuring that seals fully to the doorframe.
 Also ensure that the door wiper gasket, fitted to the bottom of the door (see fig 11).

Fig 11



**Section 4
 Operating Instructions**

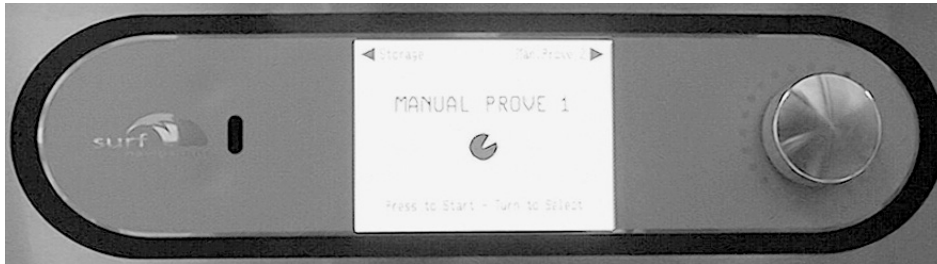

To initiate the program just press and release the dial for the program to start

Standard Operation



When mains electrical power is first applied to the controller it will carry out a self-test function, for approximately 3 seconds. During this period the display will show.



On completion of the self-test, the controller will revert to the last chill program that was run Storage, Manual Prove 1, Manual Prove 2, Manual Prove 3, ADPR 1.
 The example shows the controller in Manual Prove 1 mode with the previous and next programs indicated at the top of the display. To change the programme rotate the dial, either clockwise or anticlockwise to select the type of program you require.

Set Time and Date

For the machine to be used in automatic mode it is necessary to set the time and date.

The time and date can only be set when the controller is not running a programme.

Select one of the programmes (except 'Storage'), for example 'MANUAL PROVE 1' below left, and press and hold the dial for 2 seconds, the programme information screen will be displayed, below middle. Rotate the dial until 'SET TIME/DATE' is highlighted. Press and release the dial to access the time service screen, below right. Press and release the dial to move to the displayed time in hours and minutes, rotate the dial to alter the time, once the correct time has been achieved press and release the dial to move to 'DATE'. To change the date, month, day and year settings use the same procedure as for setting the time.

On completion press and hold the dial for 2 seconds to return to the program selection screen.

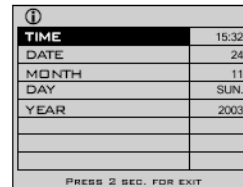
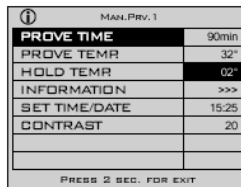

Programme Selection and Start Up

Manual Prove 1

Select the programme required, i.e. 'MANUAL PROVE 1', press and release the dial to start. The display will change to the screen below left with the flashing of 'MANUAL PROVE 1' for one minute. During this period the time setting can be adjusted to either increase or decrease the prove time in one minute increments, clockwise to increase or anti-clockwise to decrease. If no changes are required either press and release the dial or leave and after one minute the programme will start with the screen displaying below middle. This screen shows the time selected counting down and the status bar showing the operation mode. The controller will adjust the internal temperature accordingly.

During the programme by rotating the dial an additional information screen may be viewed, see below right.

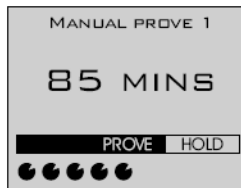
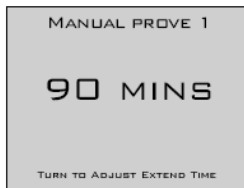

When the time reaches '0' the alarm will sound intermittently and the screen will change displaying '0', below right. The operator can check the product to determine if further proving time is required. If required rotate the dial to select the time and press to continue the process, this option can be repeated continually. If no time extension is selected or the dial is pressed while the displays show '0' the controller will automatically commence the retarding process with the turning on of the refrigeration system.

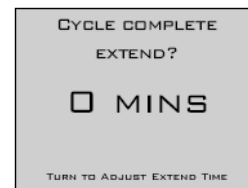
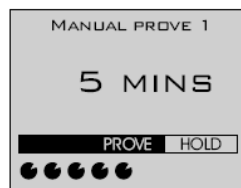
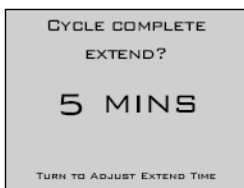

The screen will change to display the unit in 'RETARDING' mode, below left, with the temperature being displayed and 'HOLD' highlighted. The refrigeration system will lower the temperature until it reaches the storage setpoint when the screen will change to display 'STORAGE', below right. The controller will continue to operate within the storage temperature limits indefinitely initiating a time based defrost at pre-set intervals

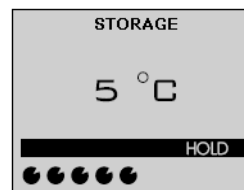
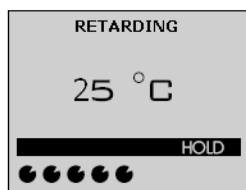

Manual Prove 2 / Manual Prove 3

The same operation function is used for manual prove 2 and 3 except that the default proving times are different, see table below.

	Manual Prove 1	Manual Prove 2	Manual Prove 3
Prove Time	90 minutes	80 minutes	70 minutes

Storage

The storage programme is selected by rotating the dial until 'STORAGE' is displayed, below left.

To start the programme press and release the dial.

The screen will change, below middle left, to display the internal temperature of the cabinet.

Rotating the dial at any time will change the screen to display air temperature, evaporator temperature and the time that the programme has been running, below middle right.

To stop the programme press and hold the dial for 2 seconds, the screen will change to display program selection menu, below right.

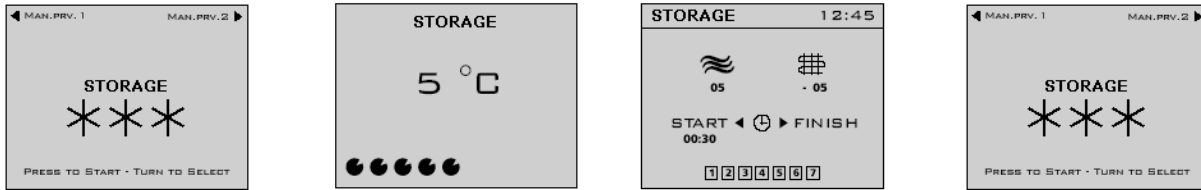

ADPR Automatic Defrost, Prove and Retard.

Rotate the dial to select the ADPR programme, see below left. When selected press and release the dial to start the programme. The screen will change to display prove time and end time, see below middle. The 'PROVE TIME' value can be changed by rotating the dial clockwise to increase and anticlockwise to decrease. When the required value is entered press and release the dial to set it. The 'END TIME' will be highlighted to display the prove time that was last set, rotate the dial to adjust the time for the prove end time.

Note: Setting of the prove end time is only possible within the next 24 hour period, minus the prove time. It is not possible to use this function as an immediate prove cycle.

Once the time has been set press and release the dial to start the programme. The screen will change to display internal air temperature, end time and function, below right.

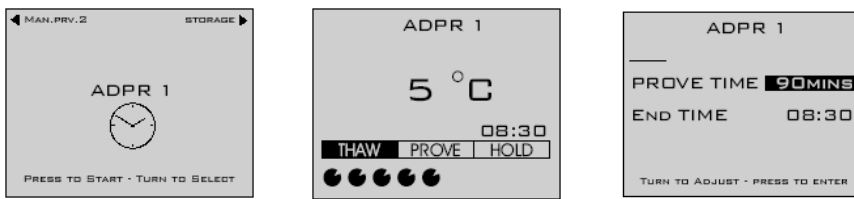

The controller will continue to control the temperature in the thaw mode until the time is reached for the prove cycle to start, below left. To achieve this the controller calculates back from the end time to determine the prove start time. Rotating the dial at any time will change the screen to display air temperature, evaporator temperature and the time that the programme has been running, below middle.

When the time reaches '0' the alarm will sound and the screen will change to display 'CYCLE COMPLETE EXTEND?' screen, below right. The operator can check the product to determine if further proving time is required. If required rotate the dial to select the time and press to continue the process, this option can be repeated continually. If no time extension is selected or the dial is pressed while the displays show '0' the controller will automatically commence the retarding process with the turning on of the refrigeration system.



The screen will change to display the unit in 'RETARDING' mode, below left, with the temperature being displayed and 'HOLD' highlighted. The refrigeration system will lower the temperature until it reaches the storage setpoint when the screen will change to display 'STORAGE', below right. The controller will continue to operate within the storage temperature limits indefinitely initiating a time based defrost at pre-set intervals

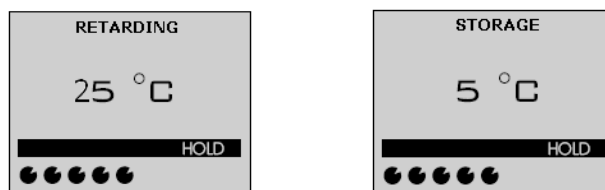

Defrost

Defrost occurs automatically only in the storage/ hold mode with the screen below being displayed.

Note: It is not possible to initiate a manual defrost.

On completion of the defrost a one minute drain period will be initiated to allow for excess melt water to drain away.

On completion the unit will revert to normal operation.

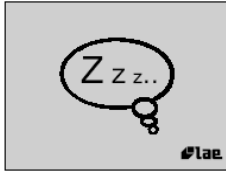
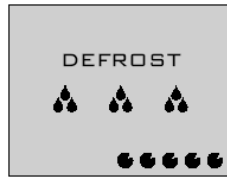

If the controller is not running a program the display will 'switch off' after 20 minutes.

When this happens the screen will display the 'sleep bubble'.

Press or rotate the dial and the display will return to showing the previous operating program that was run.

Section 5 Alarms and Warnings

High Pressure Alarm

The high-pressure alarm will be displayed if the refrigeration system exceeds the safe operating pressure. It is not possible to start any programme while this alarm situation exists.

Causes for this alarm could be:

Is the airflow restricted? Does the condenser filter require cleaning?

If the problem persists call your Foster Authorised Service Company.



Power Fail:

If the power fails for up to five minutes the unit will re-start on the resumption of the power supply without affecting the selected cycle. Longer than five minutes and the controller will enter the hold mode. To check the cycle operation look in the information screen to check the cycle time.

To re-start press and release the dial, the screen will return to the hold screen. Press and hold the dial for two seconds the display returns to the program selection.



Air Probe:

If this alarm occurs the programme will stop with the screen displayed left. The alarm will sound and can be cancelled by pressing and releasing the dial or it will stop after a set period but resound again after a pre-set time. The controller will automatically enter the storage phase until the cycle is stopped but it will not be possible to start further cycles until your Foster Authorised Service Company has rectified the fault.



Evaporator Probe:

If this alarm occurs the programme will continue with the screen displayed left. The alarm will sound and can be cancelled by pressing and releasing the dial or it will stop after a set period but resound again after a pre-set time. The controller will continue operating as normal until the cycle is stopped but it will not be possible to start further cycles until your Foster Authorised Service Company has rectified the fault.



Section 5 Cleaning Instructions

Cared for correctly stainless has the ability to resist corrosion and pitting for many years. The following weekly cleaning regime is recommended.

- a. Exterior: Use a proprietary stainless cleaner following the manufacturer instructions.
- b. Interior: Wash with soapy water, rinse with clean water and dry thoroughly.

WARNING

High alkaline cleaning agent or those containing bleaches, acids and chlorine are very harmful to stainless steel. Corrosion and pitting may result from there accidental or deliberate application.

If any of these liquids should come into contact with the unit during general kitchen cleaning, wipe down the affected area immediately with clean water and rub dry.

Never use wire wool or scouring powders on stainless steel or aluminium surfaces.

During usage all spills should be wiped clean immediately.

Condenser Filter

Clean the condenser filter, located in the front cover, when it becomes dirty (see Alarms and Warnings).

To remove the filter from its housing slide the butterfly clips away from the aperture, see below left. With the clips away from the opening, see below right, ease the filter from the front of the housing and slide it out.

Use a soft brush or vacuum cleaner to remove any dust or fluff and wash in a solution of soapy water.

Dry thoroughly and replace into the housing.

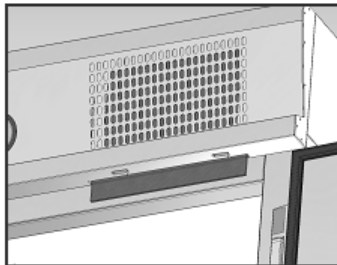
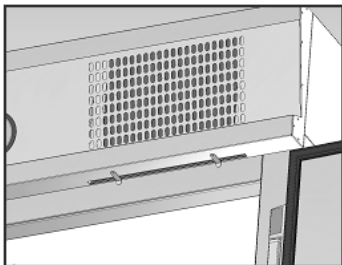

Condenser

Clean the condenser, located in the unit compartment, when it becomes dirty (see Alarms and Warnings).

Important: Disconnect the mains electrical supply to the machine prior to cleaning the condenser.

Clean the condenser using a soft brush or vacuum cleaner. NOTE: if there are any stubborn grease deposits etc left on or through the condenser call your Foster Authorised Service Company to carry out a full service.

Once the condenser has been cleaned switch the unit on.

Failure to carry out this action may invalidate the warranty of the condensing unit

Gaskets

These should be inspected on a regular basis and replaced if damaged.

To clean, wipe with a warm damp soapy cloth followed by a clean damp cloth and finally thorough dry before shutting the door.

Foster Refrigerator
Oldmedow Road
Kings Lynn
Norfolk
PE30 4JU

Tel: 01553 691122

Fax: 01553 691447

Website: www.fosterrefrigerator.co.uk

Email: sales@foster-uk.com

a Division of 'ITW (UK) Ltd'

FADRP2/OP/11/05